

特征/Features

- 饱和压降为正温度系数，易于并联使用
Easy parallel switching capability due to positive temperature coefficient in V_{CEsat}
- 低饱和压降，快速开关
Low V_{CEsat} , fast switching
- 高可靠性及热稳定性，良好的参数一致性
High ruggedness, good thermal stability very tight parameter distribution

型号/Type	打标/Marking	封装/Package
QMC40N65EH	QM40N65EH	TO-263

应用领域/Applications

- 空气压缩机/Climate Compressor
- 不间断电源/UPS
- 功率因数校正/PFC
- PTC加热器/PTC Heater

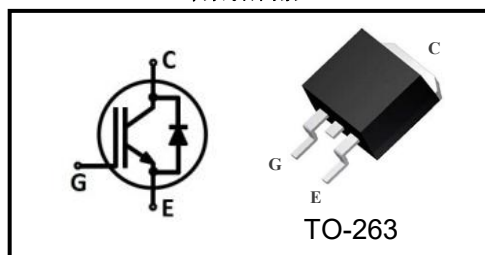

最大额定值/Maximum Rated Values ¹

Item	Symbol	Value	Unit
集电极-发射极电压 Collector-emitter voltage	V_{CE}	650	V
集电极电流 DC collector current ²	I_C	75	A
$T_C=25^\circ\text{C}$		40	
$T_C=100^\circ\text{C}$		160	
集电极脉冲电流 Pulsed collector current ³	I_{Cpuls}	160	
二极管正向电流 Diode forward current ²	I_F	40	
$T_C=25^\circ\text{C}$		20	
$T_C=100^\circ\text{C}$		120	
二极管脉冲电流 Diode pulsed current ³	I_{Fpuls}	120	
栅极-发射极电压 Gate-emitter voltage	V_{GE}	± 20	V
瞬态栅极-发射极电压 Transient Gate-emitter voltage ($t_p \leq 10\mu\text{s}$)		± 30	
耗散功率 Power dissipation	P_{tot}	250	W
$T_C=25^\circ\text{C}$		125	
$T_C=100^\circ\text{C}$			
工作结温 Operating junction temperature	T_j	-55~175	°C
储存温度 Storage temperature	T_{stg}	-55~150	

1: Reference standard: JESD-022

2: limited by T_{jmax}

3: T_p limited by T_{jmax} ;

热学特性/Thermal Characteristics

Item	Symbol	Conditions	Min.	Typ.	Max.	Unit
结-外壳热阻 IGBT thermal resistance, junction-case	R_{thJC}	-	-	-	0.6	K/W
二极管结-外壳热阻 Diode thermal resistance, junction-case	R_{thJCD}	-	-	-	1.8	
结-环境热阻 Thermal Resistance, junction-ambient	R_{thJA}	-	-	-	65	

电学特性/Electrical Characteristics

静态特性/Static Characteristics (at $T_j=25^\circ\text{C}$ unless otherwise specified)

Item	Symbol	Conditions	Min.	Typ.	Max.	Unit
集电极-发射极击穿电压 Collector-emitter breakdown voltage	$V_{(BR)CES}$	$V_{GE}=0V,$ $I_C=0.25mA$	650	-	-	V
集电极-发射极饱和电压 Collector-emitter saturation voltage	$V_{CE(sat)}$	$V_{GE}=15V, I_C=40A$ $T_j=25^\circ\text{C}$	-	1.50	-	
		$T_j=125^\circ\text{C}$	-	1.70	-	
		$T_j=150^\circ\text{C}$	-	1.80	-	
二极管正向压降 Diode forward voltage	V_F	$V_{GE}=0, I_F=20A$ $T_j=25^\circ\text{C}$	-	1.45	-	
		$T_j=125^\circ\text{C}$	-	1.30	-	
		$T_j=150^\circ\text{C}$	-	1.20	-	
阈值电压 G-E threshold voltage	$V_{GE(th)}$	$I_C=0.8mA,$ $V_{CE}=V_{GE}$		5.5		
集电极-发射极漏电流 C-E leakage current	I_{CES}	$V_{CE}=650V, V_{GE}=0V$ $T_j=25^\circ\text{C}$	-	-	0.1	mA
		$T_j=150^\circ\text{C}$	-	-	1	
栅极-发射极漏电流 G-E leakage current	I_{GES}	$V_{CE}=0V,$ $V_{GE}=20V$	-	-	250	nA
跨导 Transconductance	g_{FS}	$V_{CE}=20V,$ $I_C=40A$	-	35	-	S

动态特性/Dynamic Characteristics

Item	Symbol	Conditions	Min.	Typ.	Max.	Unit
输入电容 Input capacitance	C_{iss}	$V_{CE}=25V,$ $V_{GE}=0V,$ $f=1MHz$	-	2700	-	pF
输出电容 Output capacitance	C_{oss}		-	120	-	
反馈电容 Reverse transfer capacitance	C_{rss}		-	40	-	
栅电荷 Gate charge	Q_G	$V_{CC}=100V,$ $I_C=40A, V_{GE}=15V$	-	110	-	nC

IGBT开关特性(感性负载)/IGBT Switching Characteristics

Item	Symbol	Conditions	Min.	Typ.	Max.	Unit	
开通延迟时间 Turn-on delay time	$t_{d(on)}$	$T_j=25\text{ }^\circ\text{C}$, $V_{CC}=400\text{V}$, $I_C=40\text{A}$, $V_{GE}=0/15\text{V}$, $R_G=10\Omega$, <i>Inductive load</i>	-	85	-	ns	
上升时间 Rise time	t_r		-	55	-		
关断延迟时间 Turn-off delay time	$t_{d(off)}$		-	190	-		
下降时间 Fall time	t_f			-	40	-	
开通损耗 Turn-on energy	E_{on}			-	0.81	-	mJ
关断损耗 Turn-off energy	E_{off}			-	0.85	-	
开关损耗 Total switching energy	E_{ts}			-	1.66	-	
开通延迟时间 Turn-on delay time	$t_{d(on)}$		$T_j=150\text{ }^\circ\text{C}$, $V_{CC}=400\text{V}$, $I_C=40\text{A}$, $V_{GE}=0/15\text{V}$, $R_G=10\Omega$, <i>Inductive load</i>	-	85	-	ns
上升时间 Rise time	t_r			-	70	-	
关断延迟时间 Turn-off delay time	$t_{d(off)}$	-		210	-		
下降时间 Fall time	t_f			-	60	-	
开通损耗 Turn-on energy	E_{on}			-	1.43	-	mJ
关断损耗 Turn-off energy	E_{off}			-	1.12	-	
开关损耗 Total switching energy	E_{ts}			-	2.55	-	

二极管开关特性/Diode Characteristics

Item	Symbol	Conditions	Min.	Typ.	Max.	Unit
反向恢复时间 Diode reverse recovery time	t_{rr}	$T_j=25\text{ }^\circ\text{C}$, $V_R=400\text{V}$, $I_F=40\text{A}$, $di_F/dt=640\text{A}/\mu\text{s}$	-	150	-	ns
反向恢复电荷 Diode reverse recovery charge	Q_{rr}		-	1.06	-	μC
反向恢复峰值电流 Diode peak reverse recovery current	I_{rrm}		-	15.4	-	A
反向恢复时间 Diode reverse recovery time	t_{rr}	$T_j=150\text{ }^\circ\text{C}$, $V_R=400\text{V}$, $I_F=40\text{A}$, $di_F/dt=640\text{A}/\mu\text{s}$	-	240	-	ns
反向恢复电荷 Diode reverse recovery charge	Q_{rr}		-	2.32	-	μC
反向恢复峰值电流 Diode peak reverse recovery current	I_{rrm}		-	21.0	-	A

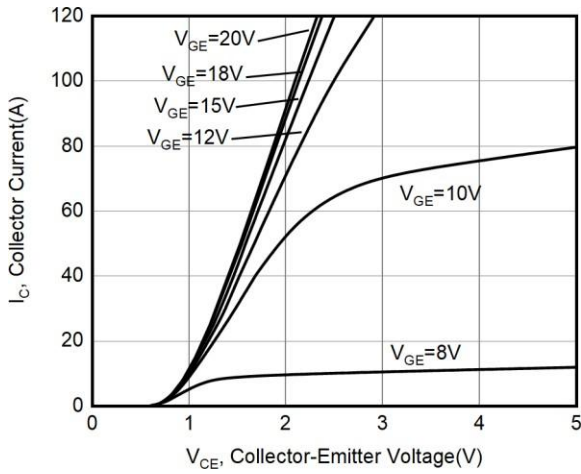

Figure 1. 典型输出特性/ Typical output characteristic ($T_j=25^{\circ}\text{C}$)

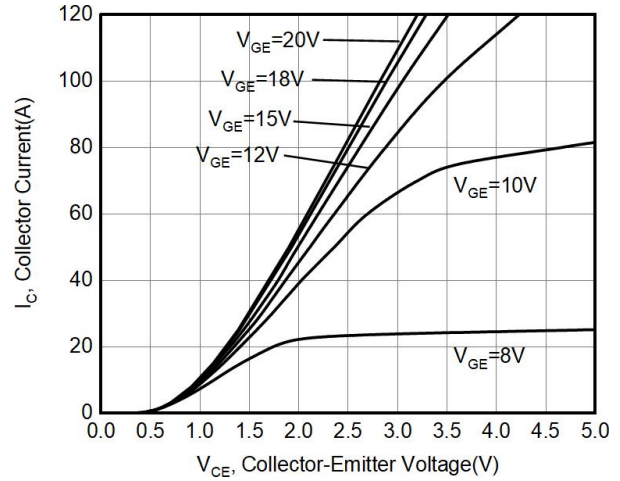

Figure 3. 典型输出特性/ Typical output characteristic ($T_j=150^{\circ}\text{C}$)

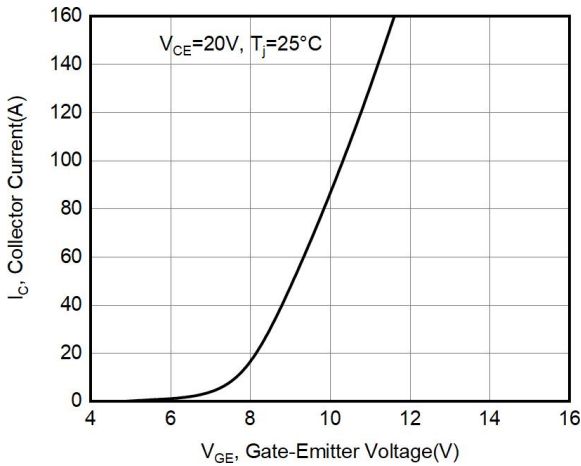

Figure 3. 典型传输特性/ Typical transfer characteristic ($T_j=25^{\circ}\text{C}$)

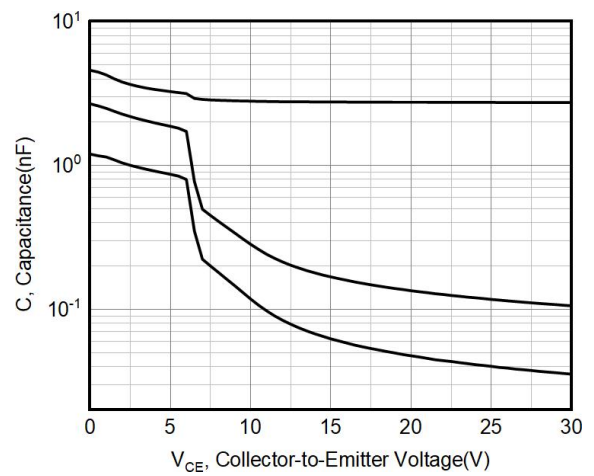

Figure 4. 电容特性/ Capacitance characteristic ($V_{GE}=0\text{V}$, $f=1\text{MHz}$)

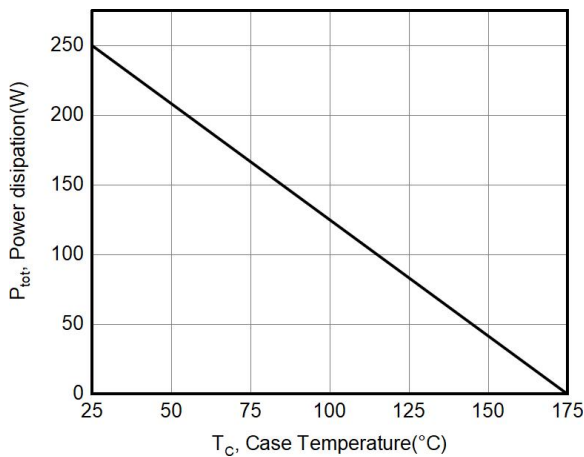

Figure 5. 功耗与外壳温度的关系曲线/Power dissipation as a function of case temperature ($T_j \leq 175^{\circ}\text{C}$)

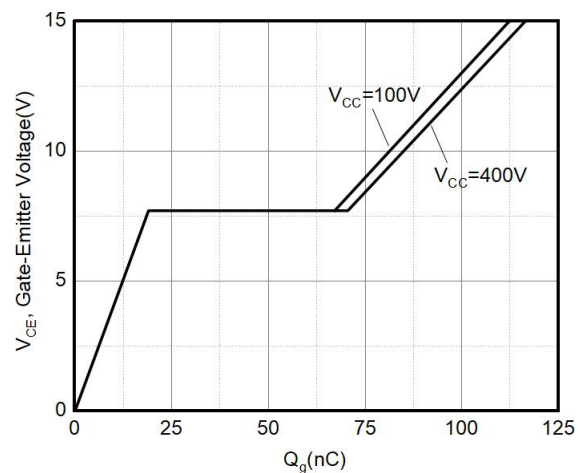

Figure 6. 典型栅极电荷/Typical gate charge ($I_C=40\text{A}$)

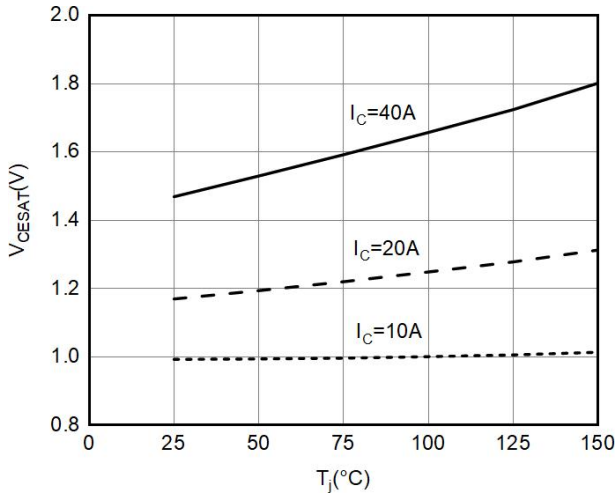

Figure 7. V_{CESAT} 作为结温的函数曲线/ V_{CESAT} as a function of junction temperature ($V_{GE}=15V$)

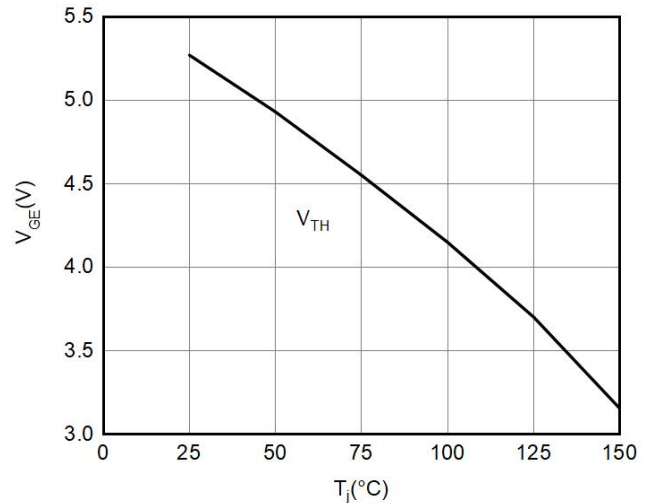

Figure 8. V_{TH} 与结温的关系曲线/ V_{TH} as a function of junction temperature ($I_{CE}=250\mu A$)

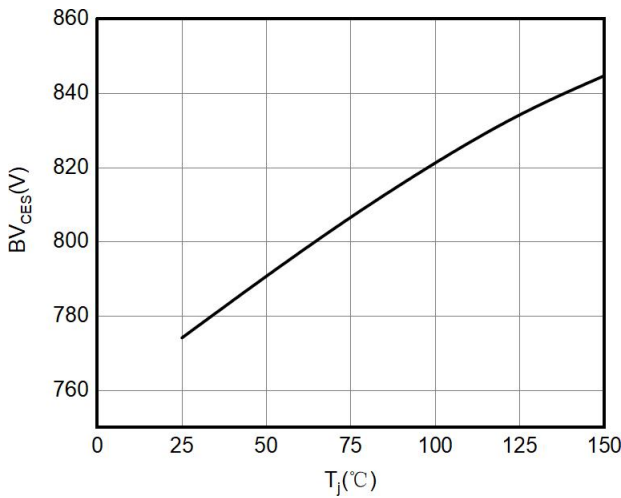

Figure 9. BV作为结温的函数曲线/BV as a function of junction temperature ($I_{CE}=250\mu A$)

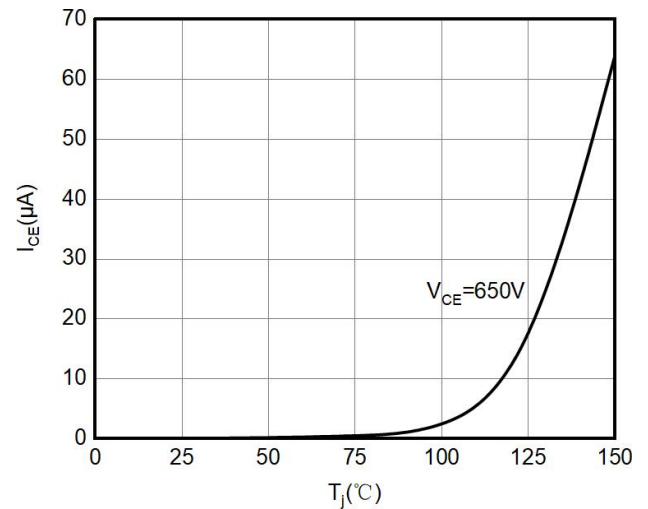

Figure 10. I_{CES} 漏电流与结温的关系曲线/ I_{CES} leakage current as a function of junction temperature

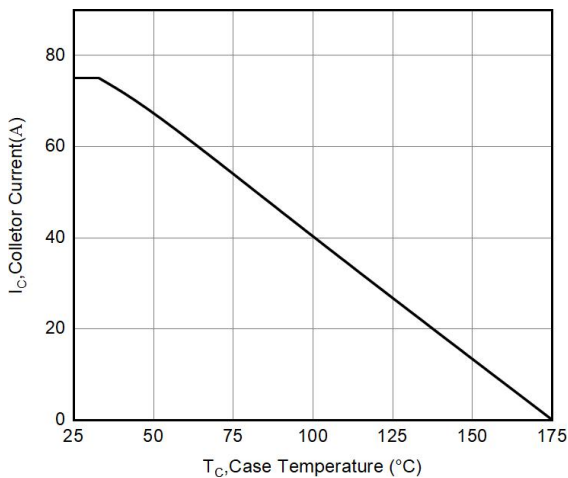

Figure 11. 集电极电流与外壳温度的关系 / Collector current as a function of case temperature ($V_{GE} \geq 15V, T_J \leq 150^\circ C$)

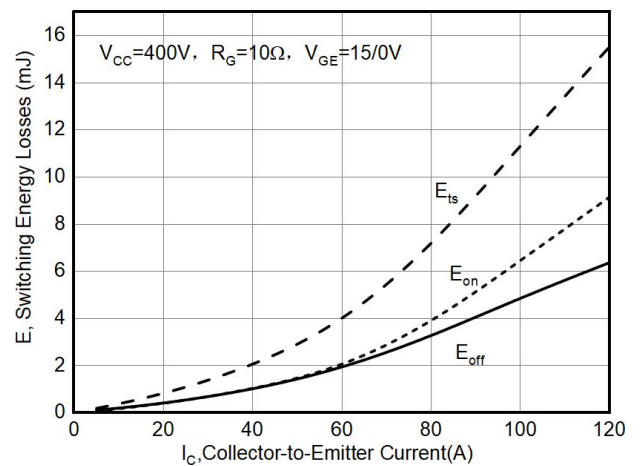

Figure 12. E_{on} , E_{off} 作为 I_C 的函数曲线 / E_{on} , E_{off} as a function of I_C ($T_J=25^\circ C$)

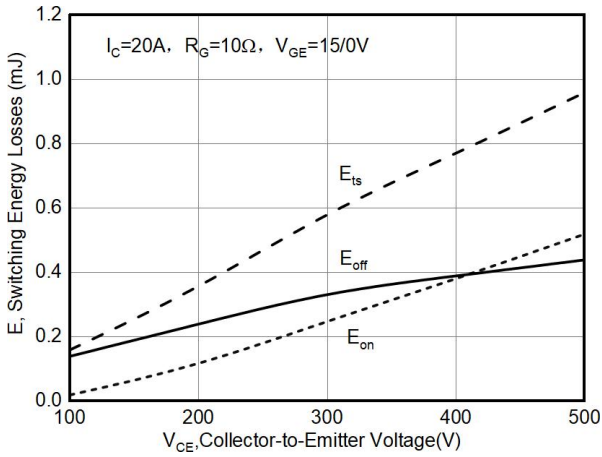

Figure 13. E_{on}, E_{off} 作为 V_{CE} 的函数曲线
 E_{on}, E_{off} as a function of V_{CE} ($T_j=25^\circ\text{C}$)

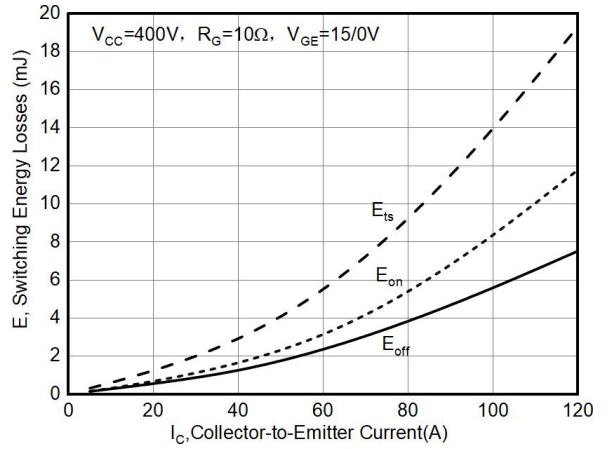

Figure 14. E_{on}, E_{off} 作为 I_C 的函数曲线
 E_{on}, E_{off} as a function of I_C ($T_j=150^\circ\text{C}$)

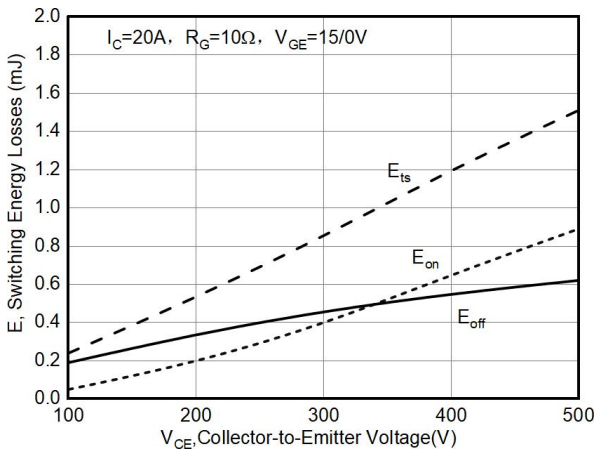

Figure 15. E_{on}, E_{off} 作为 V_{CE} 的函数曲线
 E_{on}, E_{off} as a function of V_{CE} ($T_j=150^\circ\text{C}$)

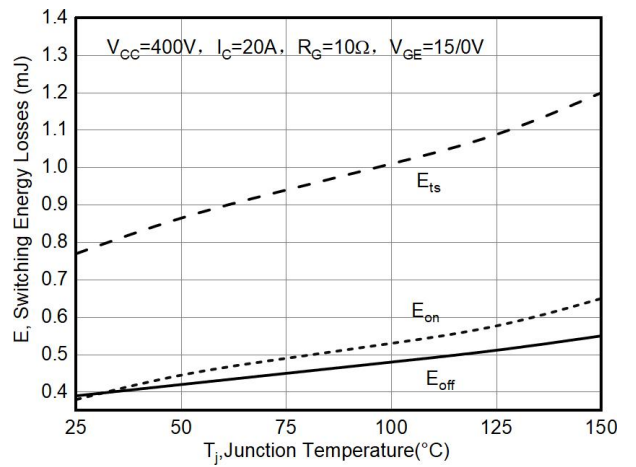

Figure 16. E_{on}, E_{off} 作为结温的函数
 E_{on}, E_{off} as a function of junction temperature

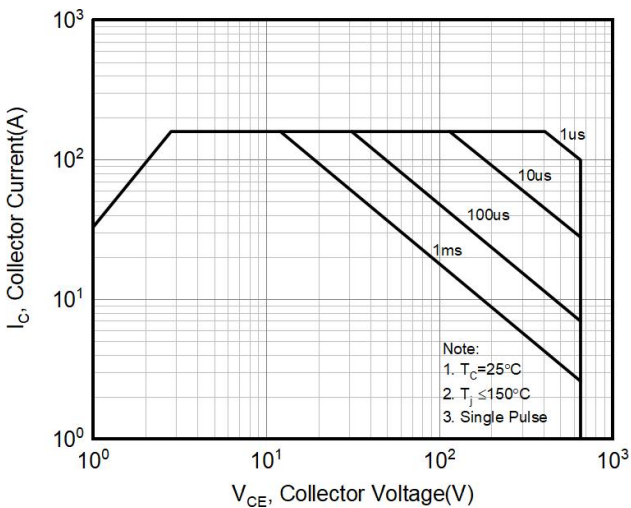
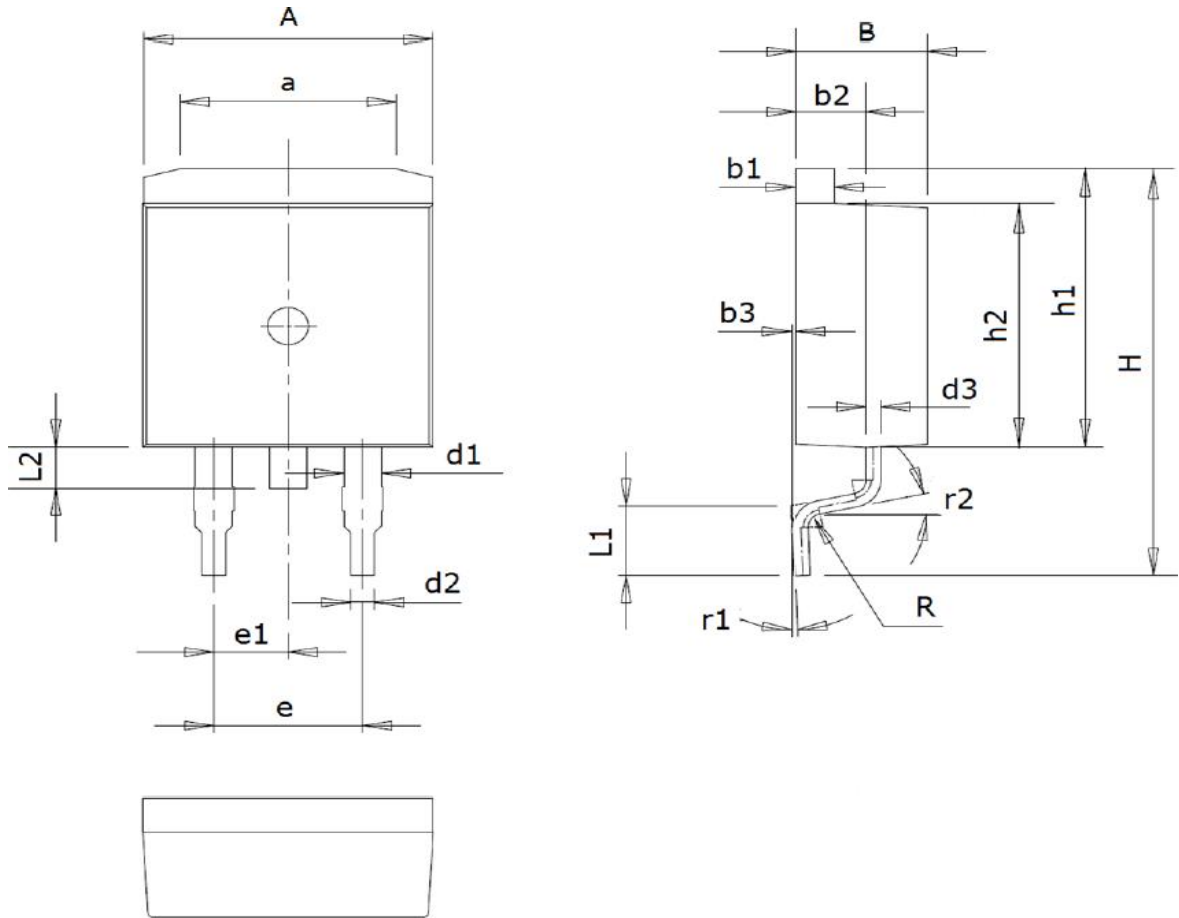

Figure 17. 正偏安全工作区/FBSOA

TO-263



Symbol	Dimensions (mm)	Symbol	Dimensions (mm)	Symbol	Dimensions (mm)
A	9.86~10.26	d2	0.7~0.96	L1	2.0~2.6
a	7.0~7.8	d3	0.3~0.53	L2	1.3~1.8
B	4.37~4.77	e	5.08	R	0.5
b1	1.22~1.42	e1	2.54	r1	0-9°
b2	2.2~2.6	H	14.7~15.5	r2	12°
b3	0~0.25	h1	10.3~10.7		
d1	1.17~1.47	h2	9.1~9.4		

修订历史/Revision History:

修订 /Revision	主题（自上次修订以来的主要变化） /Subjects (major changes since last revision)	日期 /Date
1.0	Initial Version	2023-02
2.0	Update the English and Chinese versions	2023-04

使用条件和条款

- 1、本数据手册给出的产品规格、特性、数据、材料和结构如有更改，恕不另行通知；
- 2、本数据手册提供的任何信息绝不应被视为针对任何条件或者品质而做出的保证（质量保证）。本公司对本数据手册所述的任何示例、提示或任何典型值和/或有关产品应用的任何信息的准确性和完整性不作任何保证、不承担任何法律责任；
- 3、本数据手册仅作为客户应用本公司产品时的参考资料，本公司不承诺允许使用与本数据手册中描述的产品信息相关的知识产权或任何第三方产权；
- 4、本公司致力于提高产品质量和可靠性，但所有半导体产品仍有失效的可能性。客户在设备中使用本公司产品时，要求采取足够的安全措施，以防止产品出现故障时设备发生包括（但不限于）人身伤害、火灾或其他财产损失等事故；
- 5、本产品是静电敏感器件，在产品的安装，测试，包装，储存和运输过程中必须采取防静电措施；
- 6、不要将本产品用于对可靠性要求严格的设备或系统或/和可能直接危害人类生命的设备或系统，包括但不限于医疗，救生，生命维持，太空设备，航空设备和核设备等；
- 7、未经本公司事先书面许可，不得以任何形式或任何方式传播和复制本数据手册的任何部分；
- 8、本数据手册中包含的数据仅供专业技术人员使用。客户的技术部门有责任评估产品是否适宜于其预期的应用以及针对该应用而言本数据手册中所提供的信息是否充分。如果您对本数据手册中的任何部分有任何疑问，请在使用本产品之前联系本公司。本公司对因未按照上述条件和条款使用产品而造成的任何损失概不负责。

Terms & Conditions of usage

1. The product specifications, characteristics, data, materials and structures given in this datasheet are subject to change without notice.
2. The information given in this datasheet shall in no event be regarded as a guarantee of conditions or characteristics. Qinxin Microelectronics Technology Co., Ltd. does not warrant or assume any legal liability or responsibility for the accuracy and completeness of any examples, hints or any typical values stated herein and/or any information regarding the application of the product.
3. This datasheet is only used as a reference for customers to apply our products, Qinxin Microelectronics Technology Co., Ltd. does not undertake to permit the use of intellectual property rights or any third-party property rights related to the product information described in this datasheet.
4. Although Qinxin Microelectronics Technology Co., Ltd. is committed to enhancing product quality and reliability, all semiconductor products still have a probability of failure. When using Qinxin Microelectronics semiconductor products in your equipment, you are requested to take adequate safety measures to prevent the equipment from causing accidents or events including but not limited to physical injury, fire or damage to other property if any of the products become faulty.
5. The products introduced in this datasheet are electrostatic sensitive devices and must be protected against static electricity during device installation, testing, packaging, storage and transportation.
6. Do not use the products introduced in this datasheet in equipment or systems that requiring strict reliability or/and may directly endanger human life such as medical, life-saving, life- sustaining, space equipment, aeronautic equipment, nuclear equipment submarine repeater equipment and equivalents to strategic equipment (without limitation).
7. No part of this datasheet may be disseminated and reproduced in any form or by any means without prior written permission from Qinxin Microelectronics Technology Co., Ltd.
8. The data contained in this datasheet is exclusively intended for use by professional technicians only. It is the responsibility of the customer's own technical departments to evaluate the suitability of the product for the intended application and the completeness of the product information given in this document with respect to corresponding application. If you have any question about any portion in this datasheet, contact Qinxin Microelectronics Technology Co., Ltd. before using the product. Qinxin Microelectronics Technology Co., Ltd. shall not be liable for any injury caused by any use of the products not in accordance with instructions set forth herein.