

### Features

- Integrated 6 low-loss IGBTs; (600V/30A)
- Integrated high voltage gate drive circuit( HVIC)
- Built-in undervoltage protection and overtemperature, overcurrent protection and temperature output;
- Built-in fast recovery bootstrap diode with current limiting resistor;
- Insulation class 1500Vrms / min
- High reliability and thermal stability, good parameter consistency
- Built-in temperature output

### Applications

- Air conditioning compressor
- Refrigerator compressor
- Low power invert



DIP-24H

### Ordering Information

Type NO.	Marking	Package Code
QMP30G60BTB	QMP30G60BTB	DIP-24H

### Internal Electrical Schematic

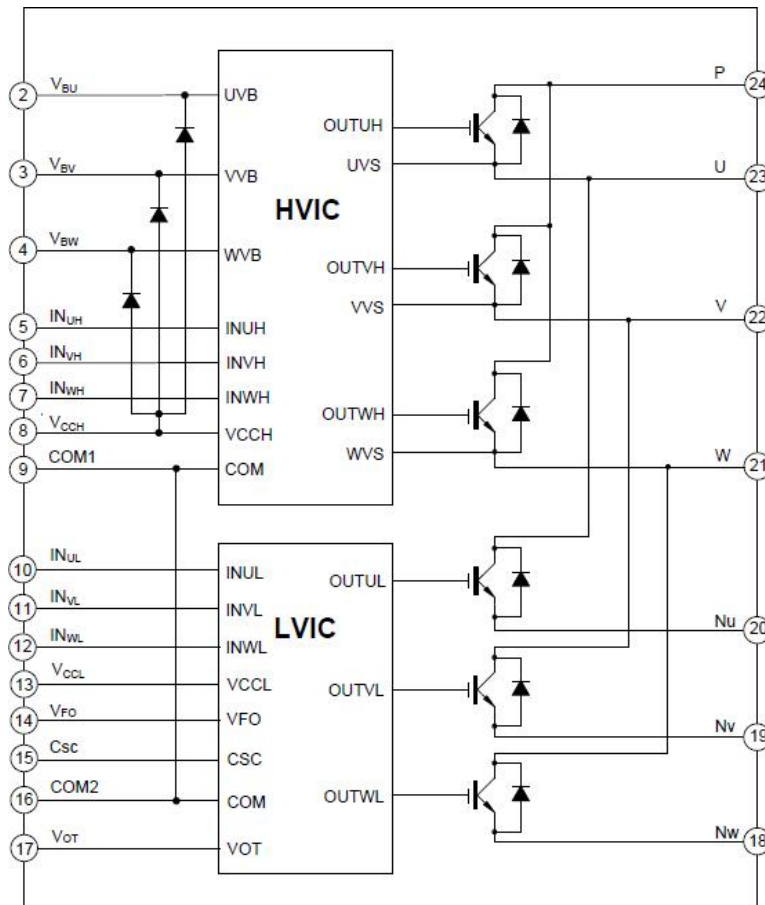

## Absolute Maximum Ratings $T_J = 25^\circ\text{C}$ , unless otherwise noted

Parameter	Symbol	Value	Unit
<b>Inverter Section</b>			
DC link supply voltage of P-N	$V_{PN}$	450	V
DC link supply voltage of P-N (surge)	$V_{PN (Surge)}$	500	V
Collector-emitter voltage	$V_{ce}$	600	V
The collector continuous current of a single IGBT, $TC=25^\circ\text{C}$	$I_C$	30	A
The peak collector current of a single IGBT, $TC=25^\circ\text{C}$ , pulse width $<1\text{ms}$	$I_{CP}$	60	A
Maximum power dissipation per module collector, $TC=25^\circ\text{C}$ , $TC=25^\circ\text{C}$	$P_C$	83	W
<b>Control section</b>			
Control the supply voltage	$V_{CC}$	20	V
High-side control voltage	$V_{BS}$	20	V
Input signal voltage	$V_{IN}$	-0.3~VCC+0.3	V
Fault output supply voltage	$V_{FO}$	-0.3~VCC+0.3	V
Operating junction temperature range	$T_J$	-40 to 150	°C
Working shell temperature range, $T_J \leq 150^\circ\text{C}$	$T_C$	-30 to 100	
Storage temperature range	$T_{STG}$	-40 to 125	°C
IGBT crusts thermal resistance	$R_{\theta JCB}$	1.5	°C/W
FRD crusts thermal resistance	$R_{\theta JCF}$	2.35	°C/W
Isolation test voltage ( 1min, RMS, $f = 60\text{Hz}$ )	$V_{ISO}$	1500	Vrms

Note 1: The maximum junction temperature of the power chip is  $150^\circ\text{C}$ , in order to ensure that IPM can work safely, it is recommended that the average junction temperature  $T_J \leq 125^\circ\text{C}$  ( $@T_C \leq 100^\circ\text{C}$ )

## Recommended Operation Conditions $T_J = 25^\circ\text{C}$ , unless otherwise noted

<b>Control section</b>					
Parameter	Symbol	Min.	Typ.	Max.	Unit
Busbar voltage between PNs	$V_{PN}$	-	300	400	V
Control the supply voltage	$V_{CC}$	13.2	-	20	V
High-side control voltage	$V_{BS}$	13.0	-	20	V
Input signal voltage	$V_{IN}$	VSS	-	VCC	V
High-side gate output voltage	$V_{HO}$	VS	-	VB	V
Low-side gate output voltage	$V_{LO}$	VSS	-	VCC	V

## Electrical Characteristics $T_J = 25^\circ\text{C}$ , unless otherwise noted

Inverter Section						
Parameter	Symbol	Condition	Min.	Typ.	Max.	Unit
Collector-emitter saturation voltage	$V_{CE(SAT)}$	$V_{CC}=V_{BS}=15\text{V}$ , $V_{IN}=5\text{V}$ $I_C=30\text{A}$ , $T_J = 25^\circ\text{C}$	-	1.7	2.2	V
FRD forward voltage	$V_F$	$V_{IN}=0\text{V}$ , $I_F=30\text{A}$ , $T_J = 25^\circ\text{C}$	-	1.5	2.0	V
Switching time (high side)	$t_{on}$	$V_{PN} = 300\text{V}$ , $V_{CC} = V_{BS} = 15\text{V}$ , $I_C = 30\text{A}$ , $V_{IN} = 0\text{V} \leftarrow \rightarrow 5\text{V}$ , The inductive load is detailed in Figure 1	-	783	-	ns
	$t_r$		-	62	-	ns
	$t_{off}$		-	722	-	ns
	$t_f$		-	48	-	ns
	$t_{rr}$		-	110	-	ns
Switching time (low side)	$t_{on}$		-	946	-	ns
	$t_r$		-	175	-	ns
	$t_{off}$		-	790	-	ns
	$t_f$		-	48	-	ns
	$t_{rr}$		-	123	-	ns
Collector-emitter current	$I_{CES}$	$V_{CE}=600\text{V}$	-	-	250	$\mu\text{A}$

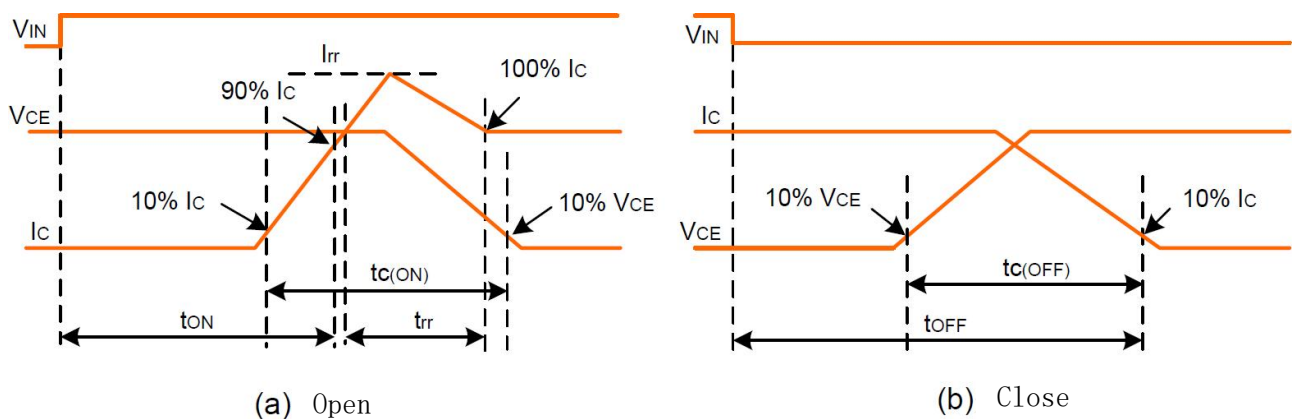
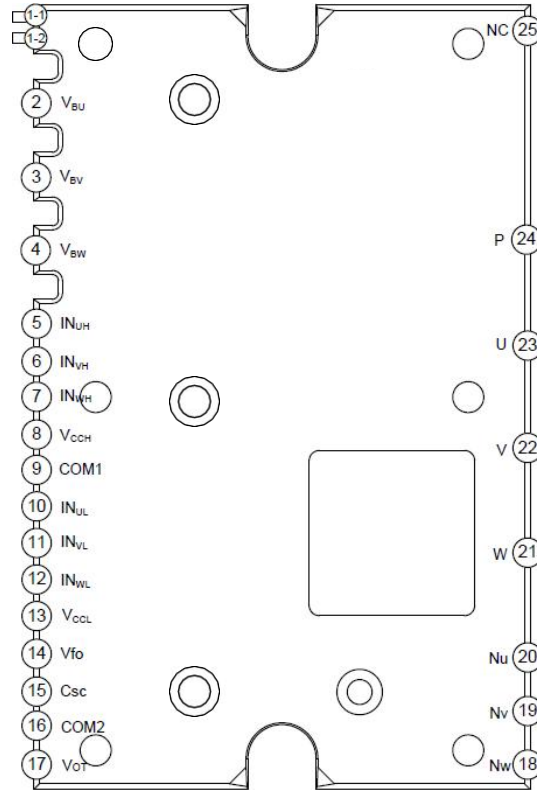

Figure 1 Definition of switching time

Control section						
Parameter	Symbol	Condition	Min.	Typ.	Max.	Unit
Quiescent VCC supply current	$I_{QCC}$	$V_{CC}=15V, V_{IN}=0V$	-	-	3.5	mA
Quiescent VBS supply current	$I_{QBS}$	$V_{BS}=15V, V_{INH}=0V$	-	75	-	uA
Fault output voltage	$V_{FOH}$	$V_{SC}=0V, V_{FO}$ pulls up 10K $\Omega$ Resistor to 5V	4.9	-	-	V
	$V_{FOL}$	$V_{SC}=1V, I_{Fo}=1mA$	-	-	0.9	V
Fault output pulse width	$t_{FO}$	Fault duration	40	-	-	us
Short-circuit protection trigger voltage	$V_{SC(ref)}$	$V_{CC}=15V$	0.415	0.46	0.505	V
Over-temperature protection	$OT_t$	LVIC temperature	100	120	140	$^{\circ}C$
Over-temperature protection hysteresis	$OT_{rh}$	LVIC Hysteresis temperature	-	10	-	$^{\circ}C$
Temperature output (Figure 2)	VOT	LVIC=25 $^{\circ}C$	0.88	1.13	1.39	V
		LVIC=90 $^{\circ}C$	2.63	2.77	2.91	V
Low-side undervoltage protection (Figure 5)	$UV_{Dt}$	$V_{CC}$ senses the voltage	10	11	12	V
	$UV_{Dr}$	$V_{CC}$ reset voltage	9	10	11	V
High-side undervoltage protection (Figure 6)	$UV_{DBt}$	$V_{BS}$ senses voltage	10	11	12	V
	$UV_{DBr}$	$V_{BS}$ reset voltage	9	10	11	V
On-threshold voltage	$V_{IH}$	Logic high	-	-	2.5	V
Shutdown threshold voltage	$V_{IL}$	Logic low	0.8	-	-	V

Bootstrap diode section						
Parameter	Symbol	Condition	Min.	Typ.	Max.	Unit
Forward voltage	$V_F$	$I_F=50mA, T_C=25^{\circ}C$	-	2.5	4.0	V
Reverse recovery time	$t_{rr}$	$I_F=10mA, T_C=25^{\circ}C$	-	50	-	ns

## Pin Assignment



## Pin Description

Pin Number	Pin name	Pin Description
1-1	COM	Internal common ground terminal
1-2	V <sub>CC</sub>	Internal power terminal, No Connection
2	V <sub>BU</sub>	U-phase high side floating IC supply voltage
3	V <sub>BV</sub>	V-phase high side floating IC supply voltage
4	V <sub>BW</sub>	W-phase high side floating IC supply voltage
5	I <sub>NUH</sub>	U-phase high side gate driver input
6	I <sub>NVH</sub>	V-phase high side gate driver input
7	I <sub>NWH</sub>	W-phase high side gate driver input
8	V <sub>CCH</sub>	High side gate drive supply voltage
9	COM1	Module common ground
10	I <sub>NUL</sub>	U-phase low side gate driver input
11	I <sub>NVL</sub>	V-phase low side gate driver input
12	I <sub>NWL</sub>	W-phase low side gate driver input
13	V <sub>CCL</sub>	low side gate drive supply voltage
14	V <sub>Fo</sub>	Fault Output
15	C <sub>sc</sub>	External capacitor, used for short-circuit current detection input and low-pass filtering
16	COM2	Module common ground
17	V <sub>oT</sub>	Temperature output terminal

18	NW	W-phase DC negative terminal
19	NV	V-phase DC negative terminal
20	NU	U-phase DC negative terminal
21	W	Output for W Phase
22	V	Output for V Phase
23	U	Output for U Phase
24	P	Positive DC-Link Input
25	NC	No Connection

### Description of the temperature output func

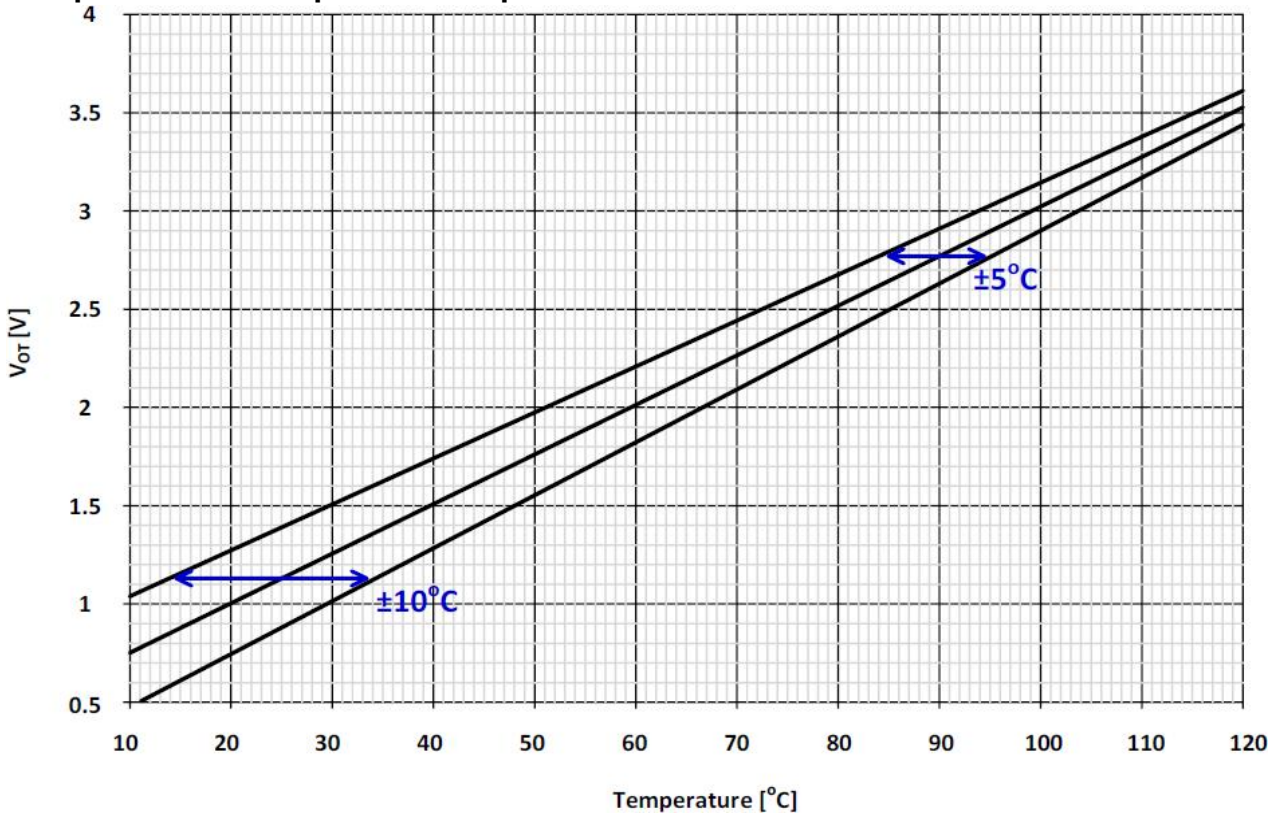

Figure 2 LVIC temperature VOT temperature characteristicstion

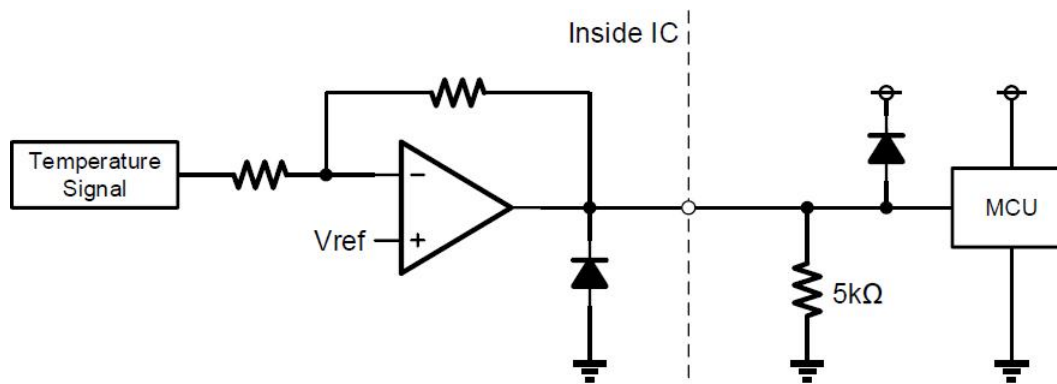
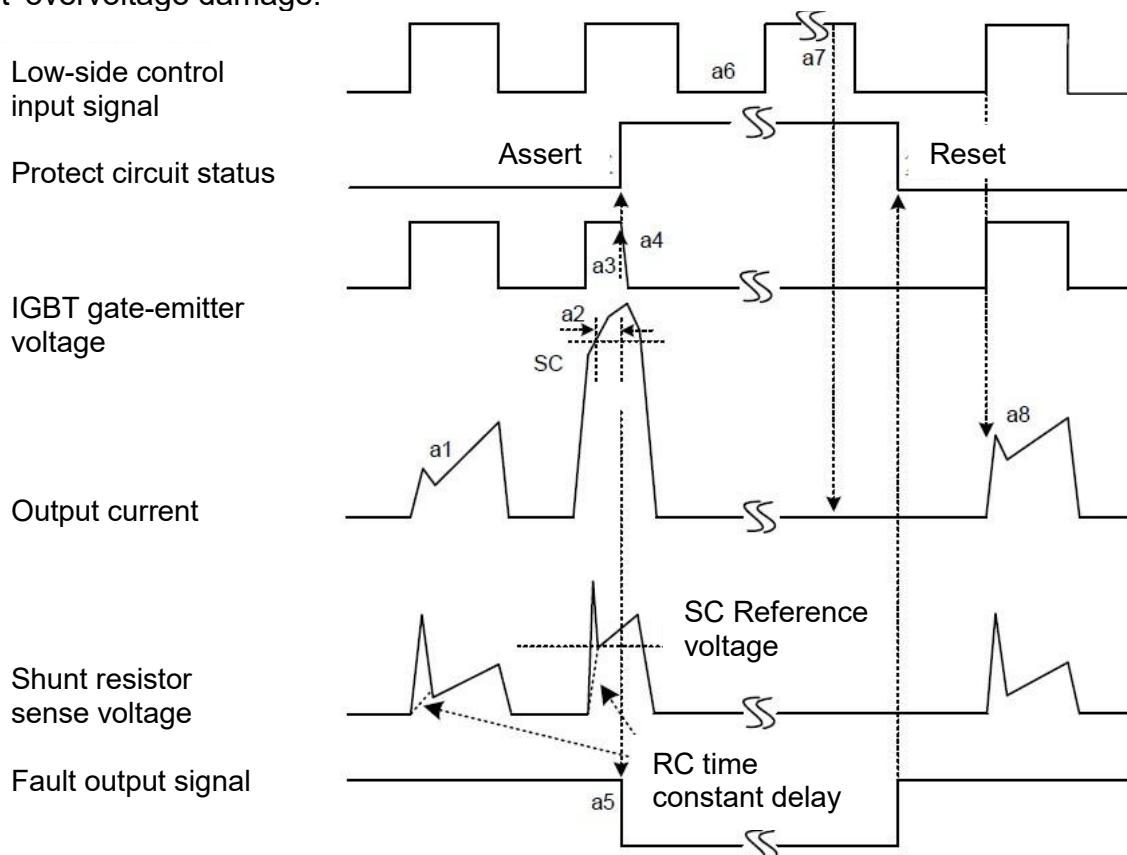

Figure 3 VOT output circuit

(1) If the temperature monitoring function is used, connect 5kΩ to the VOT pin, and ignore the internal OTP function. If the internal overtemperature shutdown function is used, keep the VOT pin on (no connection).

(2) When IPM is applied in low-voltage control (such as MCU working voltage of 3.3V), the output voltage of VOT may be greater than the control supply voltage of 3.3V in the case of a sharp rise in temperature, if the system is used for low-voltage control, it is recommended to connect a clamping diode between the control power supply and the VOT output signal to prevent overvoltage damage.



**Figure 4.Short-circuit current protection (low side only)**

(Includes external shunt resistor and RC connection).

a1: Normal operation: IGBT conducts and supplies current to the load.

a2: Short-circuit current detection (short-circuit triggering).

a3: All low-side IGBT gate hard interrupts.

a4: All low-side IGBTs are turned off.

a5: The fault output pin outputs a fixed pulse width signal ( $t_{FO} \geq 40\mu s$ ).

a6: Input is "L": IGBT shutdown state.

a7: Input is "H": Although the input is "H", the IGBT is still in the off state during this time if there is a fault output signal.

a8: Normal operation: IGBT is on, current is supplied to the load.



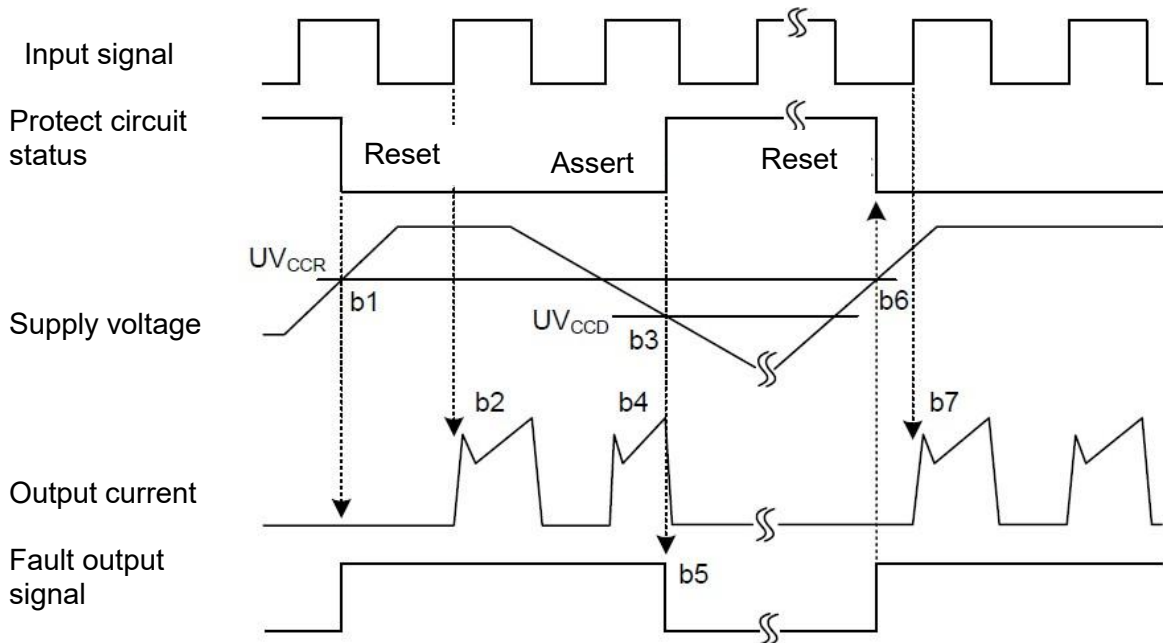

**Figure 5: Undervoltage Protection (Low Side)**

b1: The supply voltage rises to  $UV_{CCR}$  and the circuit starts working when the next input waveform arrives.

b2: Normal operation: IGBT conducts and supplies current to the load.

b3: Undervoltage detection point ( $UV_{CCT}$ ).

b4: All low-side IGBTs are turned off regardless of the signal input.

b5: The FO pin outputs a fault signal ( $t_{FO} \geq 40\mu s$ ) and continuously outputs a fault signal during undervoltage. b6: Undervoltage reset point ( $UV_{CCR}$ ).

b7: normal operation: IGBT conducts and supplies current to the load.

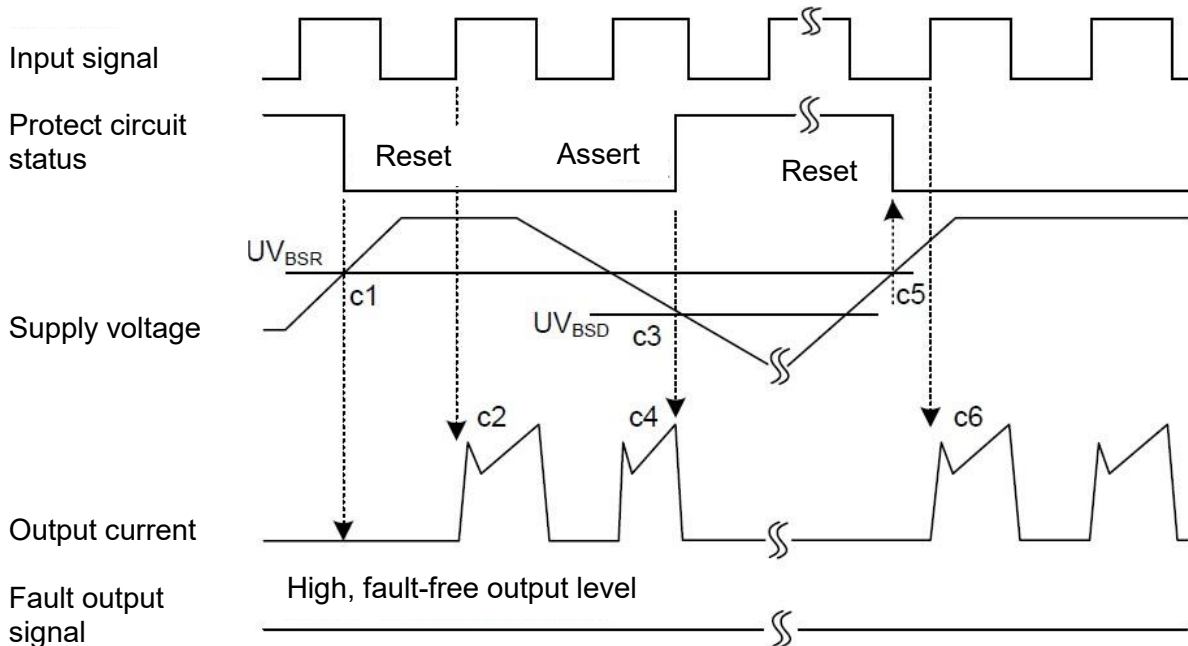

**Figure 6. Undervoltage Protection (High Side)**



- c1: The supply voltage rises to UVBSR, and the circuit starts working when the next input signal arrives.
- c2: Normal operation: IGBT conducts and supplies current to the load.
- c3: Undervoltage detection point (UVBSD).
- c4: IGBT is turned off regardless of signal input, but there is no fault signal output.
- c5: Undervoltage reset point (UVBSR).
- c6: normal operation: IGBT conducts and supplies current to the load.

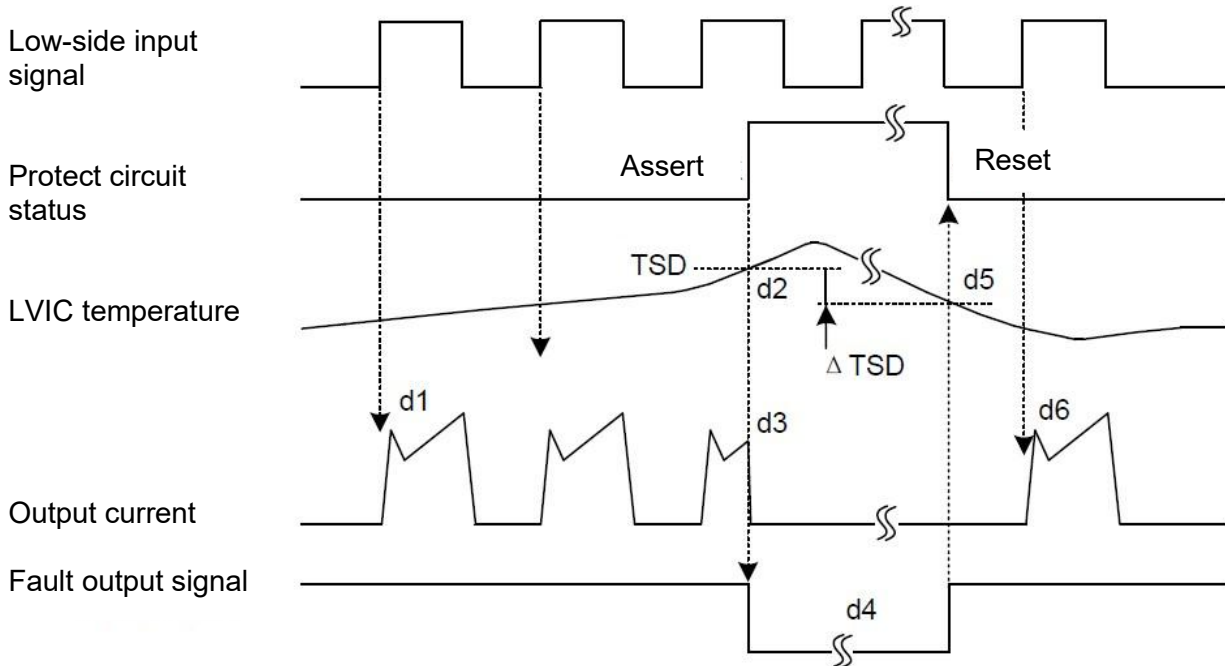

**Figure 7. Overtemperature protection (low side only)**

- d1: Normal operation: IGBT conducts and supplies current to the load.
- d2: LVIC temperature exceeds overtemperature protection trigger point (TSD).
- d3: All low-side IGBTs are turned off, regardless of the signal input.
- d4: Continuously outputs fault signals during overtemperature, and the minimum pulse width is 40us.
- d5: LVIC temperature will reset when the temperature falls below the overtemperature protection point.
- d6: When the next input signal control signal comes, the circuit enters normal working state.

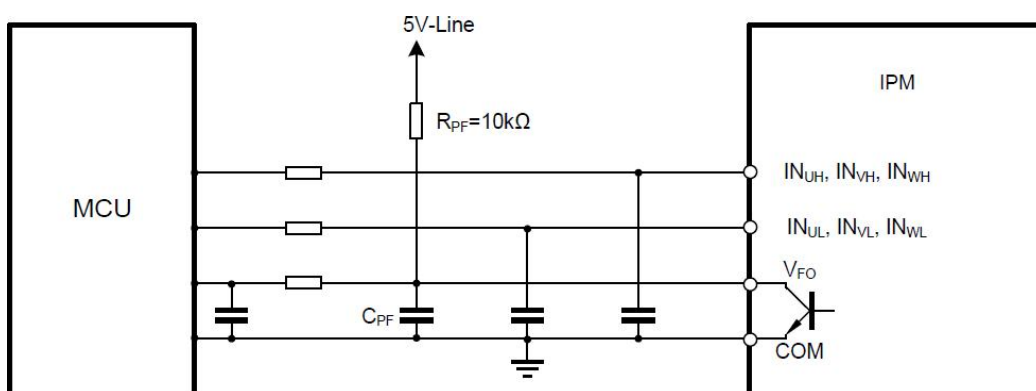

**Figure 8. MCU input/output connection circuit (recommended)**

Note: The RC coupling at each input should be adapted to the PWM control scheme and PCB layout. A 5K pull-down resistor is built into the IPM input signal section, so pay attention to the voltage drop at the input when using an external filter circuit.

## Typical application circuit diagram

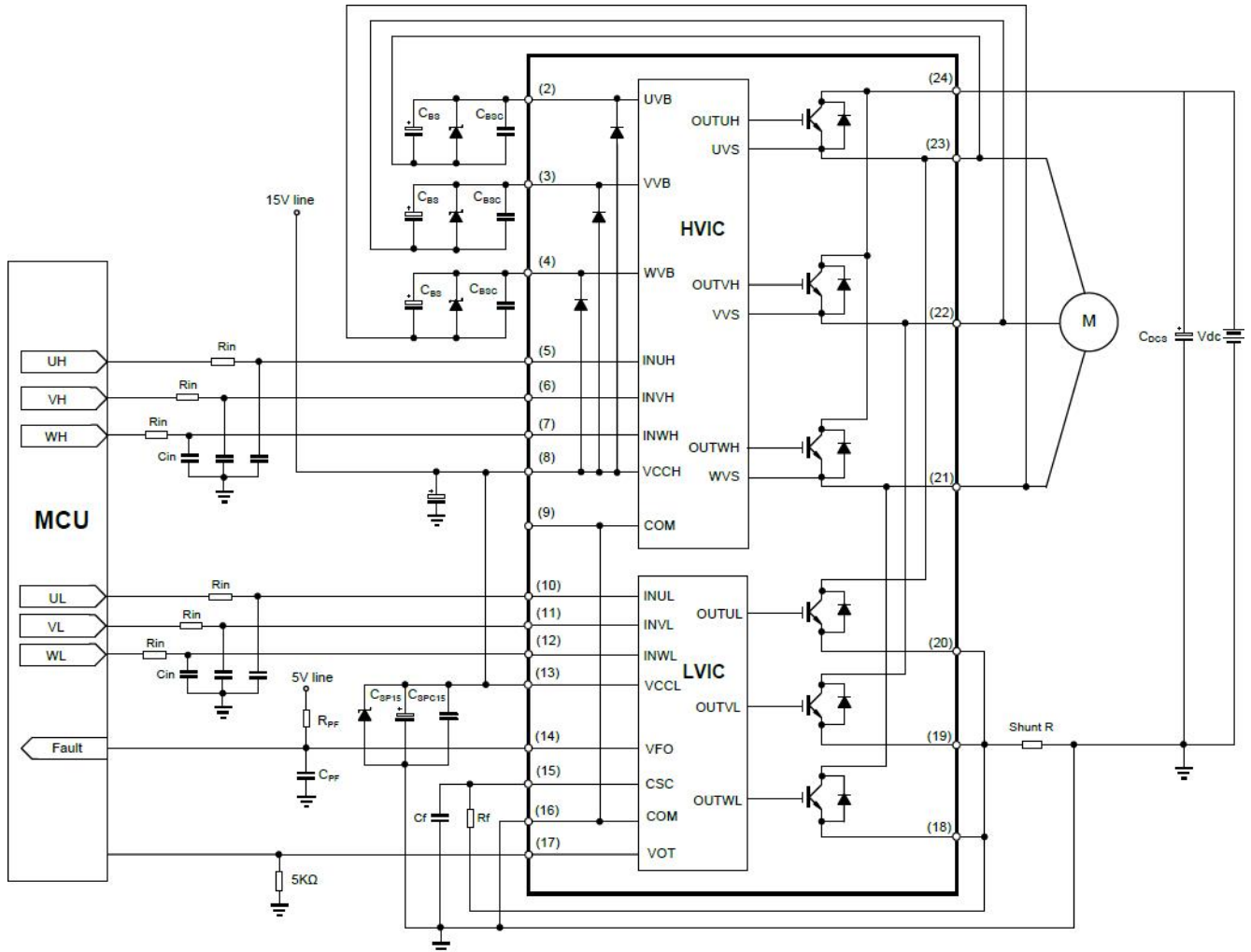

### Remark:

- (1) The connection of each input pin should be as short as possible, otherwise it may cause misoperation;
- (2) The input signal is active high, and a 5 K $\Omega$  pull-down resistor is connected to ground at the input of each HVIC channel; In addition, an RC filter circuit can be added at the input to prevent surge noise caused by incorrect input;
- (3) In order to prevent surge damage, it is recommended to add a high-frequency non-inductive flat capacitor (0.1 $\mu$ F ~ 0.22 $\mu$ F) between PNs, and the connection of the capacitor should be made Keep it as short as possible;
- (4) The connection between the current sense resistor and the IPM should be as short as possible, otherwise the large surge voltage generated by the connection inductor may cause damage;
- (5) The filter capacitor at the input of the 15V power supply is recommended to be at least 7 times that of the bootstrap capacitor CBS;
- (6) Each external capacitor should be placed as close as possible to the IPM pin;
- (7) The VFO output is open and should be pulled up to the 5V supply through the resistor so that the Ifo is 1mA;
- (8) In the short-circuit protection circuit, please select RF and CSC with time constants in the range of 1.5~2  $\mu$ s, and the wiring around RF and CSC should be as short as possible. The RF wiring should be close to the shunt resistor.



## Revision History

Revision	Date	Subjects (major changes since last revision)
1.0	2022.04	Initial version

**Disclaimer:**

**Operating conditions may differ from simulation assumptions in several aspects like level of DC-link voltage, applied gate-voltage and gate-resistor, case and junction temperatures as well as the power circuit stray-inductance. Therefore, deviations of parameters and assumptions used for the simulation and the real application may exist.**

**For these reasons we cannot take any responsibility or liability for the exactness or validity of the form's results. The form cannot replace a detailed reflection of the customers application with all of its operating conditions.**

**Accurate results depend on huge data, so with the measured data is increasing, we should be updated in real time and send it to the corresponding engineer so that he can know it in real time.**